

# EE 201 Lecture Notes

Çağatay Candan

Electrical and Electronics Engineering Dept.  
METU, Ankara.

Draft date September 17, 2014

# Chapter 1

## First Order Circuits

The current chapter contains only the discussion of two parallel capacitors. This discussion should be probably the section 3 of the finalized notes on first order circuits. Other sections will be written later (September 17, 2014).

### 1.1 Two Parallel Capacitors

Figure 1.1 shows two capacitors disconnected from each other at  $t = 0^-$ . When the switch is closed at  $t = 0$ , there will be current flowing in the loop and the capacitor voltages starts its movement. In this section, we analyze this simple looking circuit hiding some intricate results.

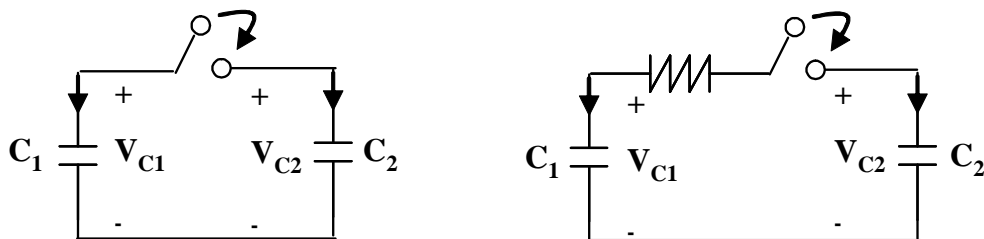

Figure 1.1: Two capacitor problem with and without resistor

We start the analysis of the circuit given on the right side of Figure 1.1. This circuit contains a resistor  $R$ , therefore its analysis is a straightforward exercise in the first order circuits. We assume that the following initial conditions,  $V_{C1}(0^-) = V_1$  and  $V_{C2}(0^-) = V_2$  for both circuits.

After the switch is closed, the circuit reduces to the one shown in Figure 1.2, which is a simple RC circuit with the time constant of  $RC_1C_2/(C_1 + C_2)$ . The

problem is the zero-input solution for the first order circuits. Hence its solution involves finding the initial conditions at  $t = 0^+$  and the time-constant which we have already noted.

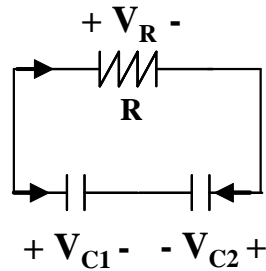

Figure 1.2: The equivalent circuit after switch closing

By an inspection of the circuit in Figure 1.2, the voltage of the resistor,  $V_R(t)$ , can be written immediately as follows:

$$V_R(t) = (V_1 - V_2)e^{-t/\tau}, \quad t \geq 0$$

We note one more time that  $\tau = RC_1C_2/(C_1 + C_2)$  is the time-constant of the circuit.

From the circuit configuration, we have  $I_{C1}(t) = -I_R(t) = -V_R(t)/R$  and  $I_{C2}(t) = I_R(t) = V_R(t)/R$  where the current directions are given in Figure 1.2. Since the current of the capacitors is available for  $t \geq 0$ , we can find the voltages of capacitors using the (i,v) relation for the capacitors:

$$V_{C1}(t) = V_1 + \frac{1}{C_1} \int_{0^+}^t I_{C1}(t') dt', \quad t > 0$$

$$V_{C2}(t) = V_2 + \frac{1}{C_2} \int_{0^+}^t I_{C2}(t') dt', \quad t > 0$$

We do the calculation for  $V_{C1}(t)$ :

$$\begin{aligned}
V_{C_1}(t) &= V_1 + \frac{1}{C_1} \int_{0^+}^t I_{C_1}(t') dt' \Big|_{I_{C_1} = -V_R/R} \\
&= V_1 - \frac{1}{RC_1} \int_{0^+}^t (V_1 - V_2) e^{-t'/\tau} dt' \\
&= V_1 + \frac{V_1 - V_2}{RC_1} \frac{e^{-t'/\tau}}{1/\tau} \Big|_{t'=0^+}^{t'=t} \\
&= V_1 + \frac{V_1 - V_2}{RC_1} \tau (e^{-t/\tau} - 1) \Big|_{\tau = RC_1 C_2 / (C_1 + C_2)} \\
&= V_1 + (V_2 - V_1) \frac{C_2}{C_1 + C_2} (1 - e^{-t/\tau}) \\
(1.1) \quad &= \frac{C_1 V_1 + C_2 V_2}{C_1 + C_2} + (V_1 - V_2) \frac{C_2}{C_1 + C_2} e^{-t/\tau}, \quad t \geq 0
\end{aligned}$$

Let's comment on the solution. By evaluating the solution at  $t = 0^+$ , we get  $V_{C_1}(t) = V_1$ , this is what we expect from the continuity of the capacitor voltage. As  $t \rightarrow \infty$ ,  $V_{C_1}(t)$  approaches the constant value of  $\frac{C_1 V_1 + C_2 V_2}{C_1 + C_2}$ . This fraction is the weighted average of the initial capacitor voltages according to the weights of  $C_1$  and  $C_2$ . For example when  $C_1 = C_2$ , the final value for  $V_C(t)$  is  $(V_1 + V_2)/2$ , i.e the arithmetic average of initial conditions.

It is possible to repeat this calculation for  $V_{C_2}(t)$  but this is not recommended. Note that  $V_{C_2}(t) = V_{C_1}(t) - V_R(t)$  due to the KVL constraint, then we have:

$$(1.2) \quad V_{C_2}(t) = \underbrace{\frac{C_1 V_1 + C_2 V_2}{C_1 + C_2}}_{V_{\text{com}}} + (V_2 - V_1) \frac{C_1}{C_1 + C_2} e^{-t/\tau}, \quad t \geq 0$$

where  $V_{\text{com}}$  is the common DC voltage of the capacitors as  $t \rightarrow \infty$ .

This last relation can also be retrieved by noting the symmetry of the circuit with respect to first and second capacitor. In other words, it is clear from Figure 1.1 that the capacitor on the left could have been labeled as  $C_2$  at the very beginning. The circuit has left-right symmetry. Therefore switching all  $V_{C_1}$  to  $V_{C_2}$ ,  $V_{C_2}$  to  $V_{C_1}$ ,  $V_1$  to  $V_2$ ,  $V_2$  to  $V_1$  in (1.1), we should get the solution for  $V_{C_2}(t)$ .

**Comment #1 (Voltage Balance):** For the sake of simplicity, let's assume that  $C_1 = C_2 = C$  and  $V_1 = V_0$  and  $V_2 = 0$ . This means that we have an identical pair of capacitors one of which is charged at  $V_0$  volts initially. For  $t > 0$ , the capacitor with  $V_0$  volts gets discharged on the resistor. The other capacitor gets charged. This process continues until the final voltage of  $V_0/2$  volts is reached. The time constant of the process is  $\tau = RC/2$ . One can interpret the situation as one of the capacitors transferring some of its charges to the other capacitor. This process of feeding the other capacitor, i.e. populating its plates with charges transferred

from the other capacitor, continues until both capacitor have the same voltage. At that time instant  $V_R = 0$  and the charge transfer stops! Note that the final value reached (the voltage balance) is independent of the resistance  $R$ . The resistance only effects the speed of the system.

**Comment #2 (Energy Calculation):** Lets calculate the energy dissipated on the resistor until the voltage balance is reached. This is the total amount of the energy dissipated on the resistor. There are two ways of calculating this value.

Power Integral: We can calculate the energy dissipated on the resistor by integrating the instantaneous power of the resistor.

$$\begin{aligned}
 W_R &= \int_{0^+}^{\infty} \frac{[V_R(t')]^2}{R} dt' \\
 &= \int_{0^+}^{\infty} \frac{(V_1 - V_2)^2 e^{-2t'/\tau}}{R} dt' \\
 &= \frac{(V_1 - V_2)^2}{R} \frac{e^{-2t'/\tau}}{-2/\tau} \Big|_{t'=0^+}^{t'=\infty} \\
 &= \frac{(V_1 - V_2)^2}{R} \frac{\tau}{2} \Big|_{\tau=RC_1C_2/(C_1+C_2)} \\
 &= \frac{(V_1 - V_2)^2}{2} \frac{C_1C_2}{C_1 + C_2}
 \end{aligned}
 \tag{1.3}$$

Conservation of Energy: The second method applies the conservation of energy principle to find the energy dissipated on the resistor. The energy dissipated is the difference of the initial stored energy and the final energy in the capacitors once the voltages are balanced.

$$\begin{aligned}
 W_R &= \{E_{C_1}(0^+) + E_{C_2}(0^+)\} - \{E_{C_1}(\infty) + E_{C_2}(\infty)\} \\
 &= \left\{ \frac{1}{2}C_1V_1^2 + \frac{1}{2}C_2V_2^2 \right\} - \left\{ \frac{1}{2}C_1V_{\text{com}}^2 + \frac{1}{2}C_2V_{\text{com}}^2 \right\} \\
 &= \left\{ \frac{1}{2}C_1V_1^2 + \frac{1}{2}C_2V_2^2 \right\} - \frac{1}{2}(C_1 + C_2)V_{\text{com}}^2 \Big|_{V_{\text{com}} = \frac{C_1V_1 + C_2V_2}{C_1 + C_2}} \\
 &= \frac{1}{2}C_1V_1^2 + \frac{1}{2}C_2V_2^2 - \frac{1}{2} \frac{(C_1V_1 + C_2V_2)^2}{C_1 + C_2} \\
 &= \frac{1}{2} \frac{(C_1 + C_2)C_1V_1^2 + (C_1 + C_2)C_2V_2^2 - (C_1V_1 + C_2V_2)^2}{C_1 + C_2} \\
 &= \frac{1}{2} \frac{C_1C_2(V_1^2 - 2V_1V_2 + V_2^2)}{C_1 + C_2} \\
 &= \frac{1}{2} \frac{C_1C_2}{C_1 + C_2} (V_1 - V_2)^2
 \end{aligned}$$

Note that the amount of energy dissipated on the resistor after switching is independent of the value of the resistor.

**Comment #3 (On Resistance  $R$ ):** It has been observed that from the solution given in (1.1) that the final value of the capacitor voltage is independent of the resistance value  $R$ . This is indeed an interesting result. Furthermore, this observation leads to the fact that the amount of energy dissipated on the resistor in the time interval of  $[0, \infty)$  is also independent of  $R$ . This last sentence has been explicitly verified by calculating the dissipated energy on the resistor in the previous comment.

Hence, we can conclude that if we have two capacitors in parallel, the final value of these capacitors is  $V_{com} = \frac{C_1V_1 + C_2V_2}{C_1 + C_2}$  for any resistance value. The resistance value does not effect the final voltage of the capacitors, but affects the time constant of the circuit. It should be clear that as  $R$  gets smaller, the circuit acts faster and the final value is reached, i.e. 5 time constants, is reached in a shorter time.

**Comment #4 (Case of No Resistance,  $R = 0$ ):** Comment #3 implies that the final value for the capacitor is independent of the resistance value in the system. Then we take liberty of taking the resistance as  $R = \epsilon$  where  $\epsilon$  is arbitrary small positive constant. For any  $\epsilon > 0$ , however small, the comment #3 is valid. We assume that the same thing is also true for  $\epsilon = 0$ ! This is small step for  $\epsilon$  but a big step in functional analysis. In spite of this unjustified step; we accept this result as it is due to its practicality as explained below.

Going back to the circuit given on the left side of Figure 1.1. This circuit does not contain any resistors. Its analysis can be confusing due to the lack of resistors. But once the comment #4 is accepted. The final value for the capacitors is

$$(1.4) \quad V_{com} = \frac{C_1V_1 + C_2V_2}{C_1 + C_2}$$

and there is some of loss energy due to switching. If you are uncomfortable with this result (loss of energy, where did the energy go?), you may consider that there is an  $\epsilon$  amount of resistance somewhere in the system. Any resistance value is okay with us, you don't even need to tell us where it is!

### 1.1.1 Analysis of Two Parallel Capacitor Circuit With No Resistance

We present an analysis for the two parallel capacitor circuit when there is no resistance in the system. The analysis of this circuit can be troubling due to the

discontinuity of the capacitors voltages at  $t = 0$  and also due to the reduction in the stored energy before and after switching. The solution for this circuit has been explained in Comment #4 of the previous section. In this section, we present an alternative method and show that this alternative is consistent with the results of Comment #4.

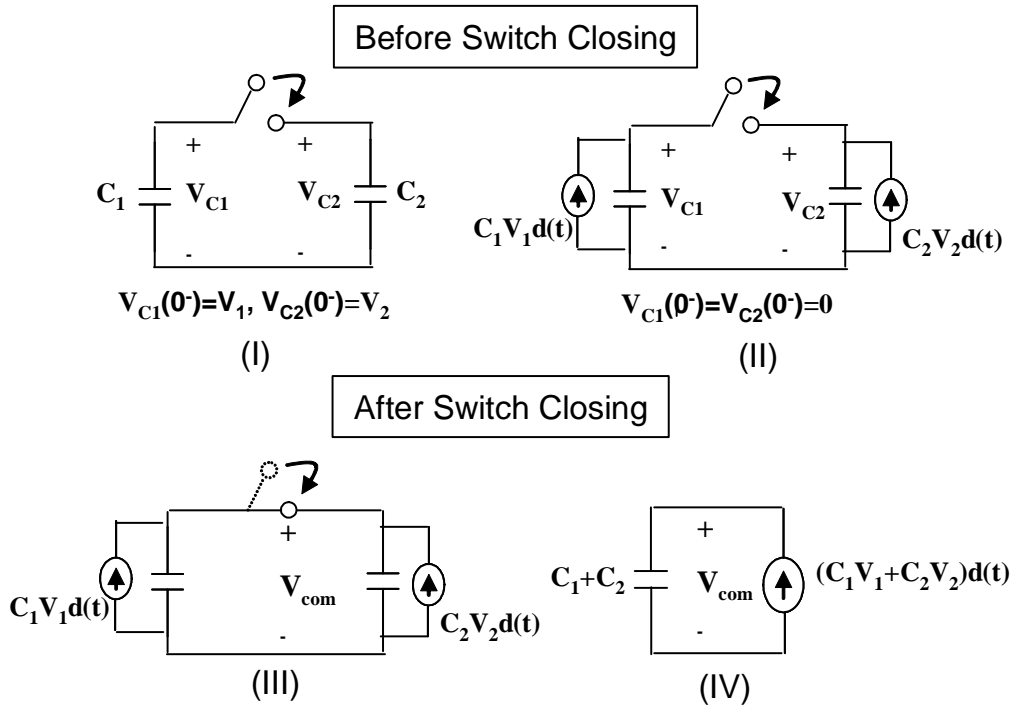

Figure 1.3: The original and equivalent circuits before and after switching

Figure 1.3 shows the circuit when the resistance in series with the switch not present. The circuit-(II) in Figure 1.3 shows the equivalent circuit in which the initial voltages for the capacitors are shown with impulsive current sources. It should be noted that the capacitors in Circuit-(II) has no charge at  $t = 0^-$ , that is they have 0 volts initially. After the replacement of the initial voltages with the current sources, two capacitors on each side of the switch have the same voltage. Hence the complication in the analysis of the circuit due to the difference in the capacitor voltages is eliminated. We should say that the difficult is swept under the rug by including the impulsive sources in the system, but it should be clear that the circuit-(II) can be worked out like any other circuit containing impulsive sources.

Once the switch is closed, two capacitors have the common voltage of  $V_{\text{com}}$  as shown in Circuit-(III). This voltage is not known. To find this voltage, we keep the nodes between which the  $V_{\text{com}}$  defined fixed and combine all other components to simplify the circuit. By simple component combining, we get the circuit-(IV). Note

that Circuit-(IV) and Circuit-(II) have the same  $V_{\text{com}}$  value, but all other circuit-(II) variables are invisible in Circuit-(IV).

It should be noted that  $C_1 + C_2$  Farad capacitors has initial voltage of 0 volts, since  $C_1$  and  $C_2$  Farad capacitors in Circuit-(II) are initially empty. Then the common voltage of two capacitors can be written as follows:

$$\begin{aligned} V_{\text{com}}(0^+) &= V_{\text{com}}(0^-) + \frac{1}{C_1 + C_2} \int_{0^-}^{0^+} (C_1 V_1 + C_2 V_2) \delta(t') dt' \\ &= \frac{C_1 V_1 + C_2 V_2}{C_1 + C_2} \end{aligned}$$

This result matches our earlier findings in the analysis of the circuit with the resistor.

**A Second Way For  $V_{\text{com}}$  Calculation:** Another way of finding  $V_{\text{com}}(0^+)$  is recognizing that the circuit-(IV) represents an initially charged  $C_1 + C_2$  Farad capacitor capacitor. The initial voltage of the  $C_1 + C_2$  Farad capacitor at  $t = 0^+$  is  $V_{\text{com}}$  and this value can be written as an impulsive current source having the functional form of  $(C_1 + C_2)V_{\text{com}}\delta(t)$ . Comparing  $(C_1 + C_2)V_{\text{com}}\delta(t)$  with the current source in Circuit-(IV) gives us the relation for  $V_{\text{com}}$  voltage.

**A Third Way via Conservation of Charge Principle:** It is also possible to calculate the final voltage at  $t = 0^+$  through the conservation of charge principle. The principle states that the total charge over the capacitors before and after should be same. (It is clear that the system is closed, therefore this statement is obviously true.)

$$\begin{aligned} Q_{\text{Total}}(0^-) &= Q_{\text{Total}}(0^+) \\ C_1 V_1 + C_2 V_2 &= (C_1 + C_2) V_{\text{com}} \end{aligned}$$

$Q_{\text{Total}}(t)$  appearing in the last equation refers to the total charge stored in the capacitors at time  $t$ . By solving for  $V_{\text{com}}$ , we get  $V_{\text{com}} = \frac{C_1 V_1 + C_2 V_2}{C_1 + C_2}$ .

**Consistency of Energy Relations:** It is also important to calculate the total energy in the system before and after switching. The initial and final energy in the system can be written as follows:

$$\begin{aligned} E_{\text{cap}}(0^-) &= \frac{1}{2} C_1 V_1^2 + \frac{1}{2} C_2 V_2^2 \\ E_{\text{cap}}(0^+) &= \frac{1}{2} (C_1 + C_2) V_{\text{com}}^2 = \frac{1}{2} \frac{(C_1 V_1 + C_2 V_2)^2}{C_1 + C_2} \end{aligned}$$

You can easily check that  $E_{\text{cap}}(0^+) < E_{\text{cap}}(0^-)$  unless  $V_1 = V_2$ . (This result can be shown by using convexity of  $(\cdot)^2$  function.) The only other component in the system is the switch. Lets calculate the energy dissipated on the switch. Switch is the only



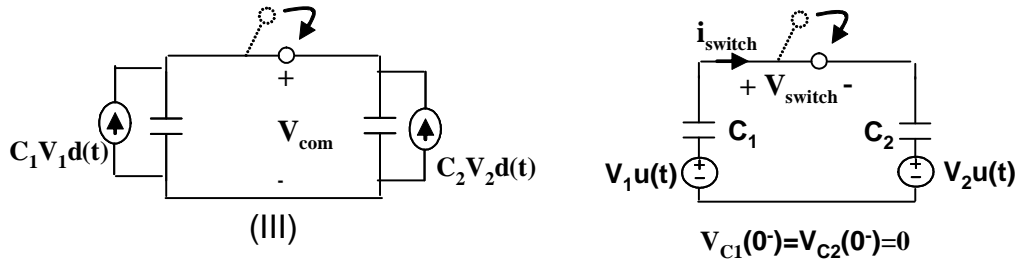

Figure 1.4: Circuit-(III) of Figure 1.3 and its equivalent

suspect for the vanishing energy. (Here we are assuming that the switch is a large valued resistor whose resistance value is suddenly changed from 0 to  $\infty$  at  $t = 0$ .)

Figure 1.4 presents the Circuit-(III) from Figure 1.3 and another equivalent circuit. We have chosen to use the equivalent circuit given on the right hand side of Figure 1.4, since our interest has shifted from  $V_{\text{com}}$  calculation to  $V_{\text{switch}}$ ,  $I_{\text{switch}}$  calculation. From the equivalent circuit given in Figure 1.4, we can note the following:

$$V_{\text{switch}}(t) = (V_1 - V_2)u(-t) = \begin{cases} V_1 - V_2, & t < 0 \\ 0, & t > 0 \end{cases}$$

The equation above represents the opening and closing of the switch. The current passing through the circuit is

$$I_{\text{switch}}(t) = \frac{C_1 C_2}{C_1 + C_2} (V_1 - V_2) \delta(t)$$

The current equation can be checked by noting that the voltage across the series combination of  $C_1$  and  $C_2$  is  $(V_1 - V_2)u(t)$ . (Note that in the calculation related to the circuit variables of the switch, we simplify all the circuit components except the ones associated with the switch. Hence the branch of the switch is fixed and we are combining voltage sources, which are in series, and the capacitors, which are also in series.)

If the switch is treated as a circuit component, the energy dissipated on this component is:

$$\begin{aligned} E_{\text{switch}} &= \int_{0^-}^{0^+} V_{\text{switch}}(t') I_{\text{switch}}(t') dt' \\ &= \frac{C_1 C_2}{C_1 + C_2} (V_1 - V_2)^2 \underbrace{\int_{0^-}^{0^+} u(-t') \delta(t') dt'}_{1/2} \\ &= \frac{1}{2} \frac{C_1 C_2}{C_1 + C_2} (V_1 - V_2)^2 \end{aligned}$$

The integral of  $u(-t')\delta(t')$  in between  $0^-$  and  $0^+$  is equal to  $1/2$  since “half of the area” under the impulse is nulled by  $u(-t)$ . (Experienced readers should remember the fact that  $\delta(t) = \delta(-t)$ , i.e.  $\delta(t)$  is an even function.)

From this calculation the energy dissipated on the switch,  $E_{\text{switch}}$  is found as  $\frac{1}{2} \frac{C_1 C_2}{C_1 + C_2} (V_1 - V_2)^2$ . By comparing this value with the power dissipated on the resistor given in (1.3), we can note that the amount of dissipated energy is identical in both cases. Hence  $E_{\text{switch}} + E_{\text{cap}}(0^+) = E_{\text{cap}}(0^-)$  (as in the resistive case) and therefore energy is conserved.

This shows that there is no inconsistency in the analysis if the switch is treated as a circuit component, i.e. a time-varying resistor. If you are uncomfortable with the operations with impulsives, i.e. impulsive current or “half the area” argument, you can always assume that there is an  $\epsilon$  amount of resistance in series with the switch. You get the same result.

## 1.2 Mechanical Analogy: Ballistic Pendulum

In the previous section, a *mathematical description* is given for the experiment of abruptly connecting two capacitors having different initial voltages in parallel. We call the earlier description mathematical since this description takes the mathematical abstractions on the physical phenomena granted. These abstractions are the idealized mathematical models related with the lumped circuit assumption, ideal components, zero-resistance connections etc. With the phrase of mathematical description, we would like to convey that the outcome of this experiment is predicted by a proper manipulation of the mathematical abstractions via the rules of analysis. The final result is (hopefully) a good approximation of what is going on in practice. This is the case if the unmodeled effects have negligible contribution to the final result. We would like to reiterate that the analysis results can be interpreted as the predictions for the actual experiment and they are only valuable if they match the experiments.

In this section, we visit a simple problem from mechanics to establish an analogy with the two parallel capacitors experiment. The analogy is constructed with the ballistic pendulum experiment. In the early days of hand-held gun (rifles, revolvers) testing, the speed of the bullet exiting the barrel was measured with a ballistic pendulum. Today, we have very fast cameras and some other highly sensitive measurement instruments to accurately estimate the exit velocity and ballistic pendulums are utilized less often.

The ballistic pendulum set-up consists of a massive pendulum attached to a pivot point around which it can freely rotate, as shown in Figure 1.5. The bullet ex-

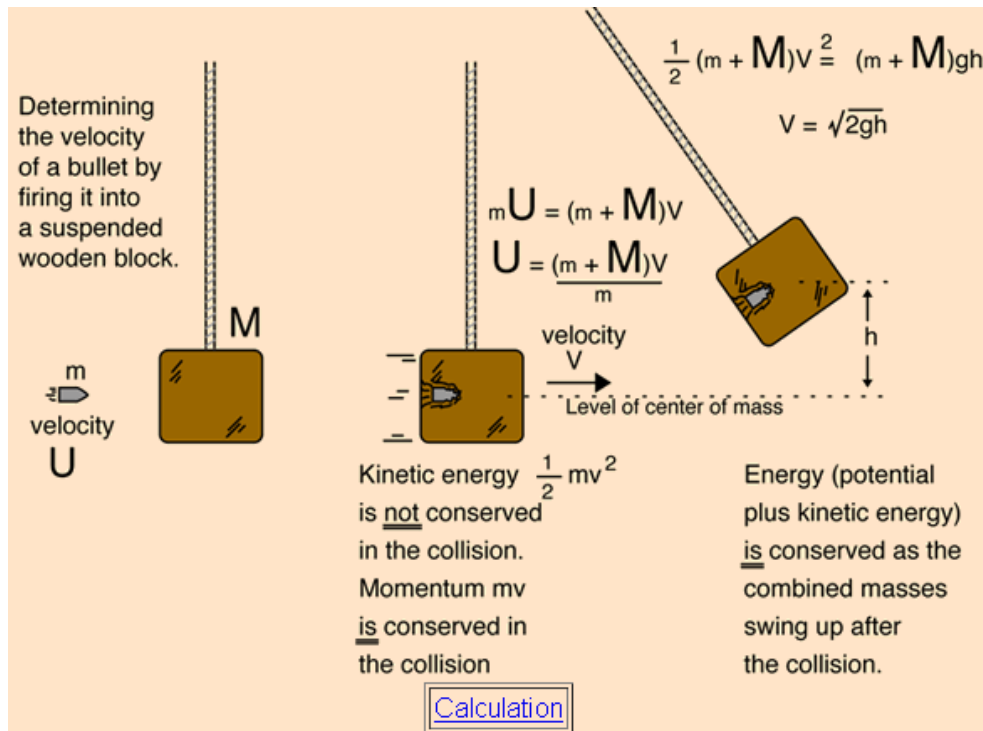

Figure 1.5: Ballistic Pendulum from <http://hyperphysics.phy-astr.gsu.edu/Hbase/balpen.html>

iting barrel with a large kinetic energy hits the pendulum and swings the pendulum. The goal is to measure the maximum height (or the horizontal displacement) to determine the exit speed. Since this is a problem of mechanics, we use the concepts, the abstractions, such as the conservation of momentum, conservation of energy from physics and apply mathematical analysis on these abstractions. More specifically, we will be manipulating the relations such as  $mgh$ ,  $1/2mv^2$ ,  $m_1v_1 = m_2v_2$ ,  $F = ma$  etc.

**Solution 1 (Wrong):** This solution is based on the conservation of energy. We may say that the kinetic energy of the bullet at the exit is totally converted into the potential energy of the pendulum at the peak position. By equating the kinetic and potential energies, we get the following equation:

$$\frac{1}{2}mv^2 = (m + M)gh.$$

In this equation,  $m$  and  $M$  denotes the mass of the bullet and pendulum, respectively. The variable  $v$  is the unknown exit velocity,  $g = 9.8m/s^2$  is the gravitational acceleration,  $h$  is the height of the pendulum. From this equation, we can get the exit speed as  $v = \sqrt{2\frac{m+M}{m}gh}$ . Please note that in this solution, we did not make

use of any other conservation laws.

**Solution 2 (Correct):** This solution starts with the conservation of momentum. At the instant the bullet hits the pendulum, we can write the following equation via the conservation of momentum:

$$(1.5) \quad mv = (m + M)v'.$$

In this equation,  $v'$  is the final velocity of the pendulum and bullet block after collision. It is assumed that bullet and pendulum act as a single object of mass  $m + M$  after the collision. If the pendulum-bullet combination reaches the height of  $h$ , we can write the following from the conservation of energy principle

$$\frac{1}{2}(m + M)(v')^2 = (m + M)gh.$$

From this equation, we can write  $v' = \sqrt{2gh}$  and using this result in (1.5) we get  $v = \frac{m+M}{m}\sqrt{2gh}$ . It should be noted that this result is different from the earlier one. The question to be answered is which one of these analysis is correct, i.e. fits the experiment.

Please note that in the second solution, the initial energy of the system (the kinetic energy of the bullet) is not equal to the potential energy of pendulum-bullet block at the maximum height. This solution carries the additional burden of explaining what happens to the lost energy.

The solution of this mystery is given by studying the type of collisions. As you may remember, there are two types of collisions, elastic and inelastic. Energy is conserved in the elastic collision, that is the total energy of particles participating in the collision before and after are the same. This situation is indeed rare. If you drop a basketball from a height  $h$ ; after it hits the ground, it can not exactly reach the same height. This is the reason that the ball bounces a few times and comes to a stop. The initial energy of the ball is converted into heat through several interactions with the ground. A tennis ball hitting a racket has a better chance of regaining its initial energy if the racket strings are not too stiff. A trampoline, over which children can enjoy jumping up and down, has even a better chance of delivering back the energy after each impact. In general, if the parties involved in the collision have the capability of storing and delivering energy without the deformation of its physical properties, they can be considered as elastic and this type of collision is called elastic collision.

The inelastic collisions cause deformation of the objects participating in the collision. The energy used to deform the object can be considered as lost. In many problems, the deformation effects are related with the material properties and they are difficult to account for. For the pendulum problem, the bullet sticking into the

pendulum experiences a severe resistance and slows down. The slowing down bullet increases the body temperature of the pendulum. The energy dissipated to deform the pendulum and the increase of temperature due to resistance of the block to the motion of the bullet sums up to the energy lost during the whole process.

Going back to the ballistic pendulum problem, the correct explanation of the events taking place is given by Solution 2. The collision is inelastic for this experiment and there is a significant energy loss during the collision. It should be noted that Solution 1 does not take into account any other possible energy losses during the experiment. As noted before, the energy losses taking place during the collision are difficult to account using the simple relations of mechanics. Hence, the effects that are not present in the abstraction of the problem renders this solution wrong!

If we revisit the two parallel capacitors problem, we can see that the conservation of charge and the conservation of energy principles are clashing. The solution we have provided in the earlier section utilizes the conservation of charge principle first. It is similar to the utilization of the conservation of momentum principle for the ballistic problem. As we have seen earlier, the final stored energy after two capacitors put in parallel is less than the total initial energy of capacitors. This is also similar to the energy loss after collision in the ballistic problem. Please remember that for the ballistic problem, we have explained this loss by the inelastic collision. The energy difference is due to effects that are not accounted for in simple mechanics. Namely, the mechanical energy is converted into heat energy! In analogy, we do not try to explain what happens to the energy lost during switching. Our models can not cover this. You can consider that the energy is lost due to the radiation during switching. This should be good enough for now.